

HPS128-LT-S – Hybrid pyroelectric linear array with 128 responsive elements and integrated CMOS multiplexer

Description

The pyroelectric linear array 128-LT is a hybrid detector with 128 responsive elements and an integrated CMOS multiplexer.

The pyroelectric chip consists of lithium tantalate (Li-TaO₃). The size of the responsive elements is (90 x 500) μm² with a pitch of 100 μm (90 x 1000 μm² available on request).

The multiplexer includes low-noise preamplifiers for each pixel, analogue switches and an output amplifier. The pre-amplifiers transform the signal charges of each pixel in a signal voltage, realize a band limiting and give the amplified signal to the sample&hold for the read-out process. The digital inputs are CMOS compatible.

For the measurement of the detector temperature a sensor (type AD 590) is integrated. It provides a temperature proportional current.

The pyroelectric chip and the read-out circuit are arranged in a metal hermetic package with an infrared window. It determines the spectral responsivity.

For the measurement of the infrared radiation it is necessary to chop the radiation flux.

Features

- 128 responsive elements arranged in a line
- Coated germanium or silicon as infrared window
- Broad band windows or special filters are possible on request
- NEP (128 Hz) = 7 nW (typical)
- Dynamic range > 75 dB
- Integrated CMOS multiplexed
- Good long-term stability
- Simple mode of operation
- Operation at ambient temperatures
- Small package

Readout-circuit

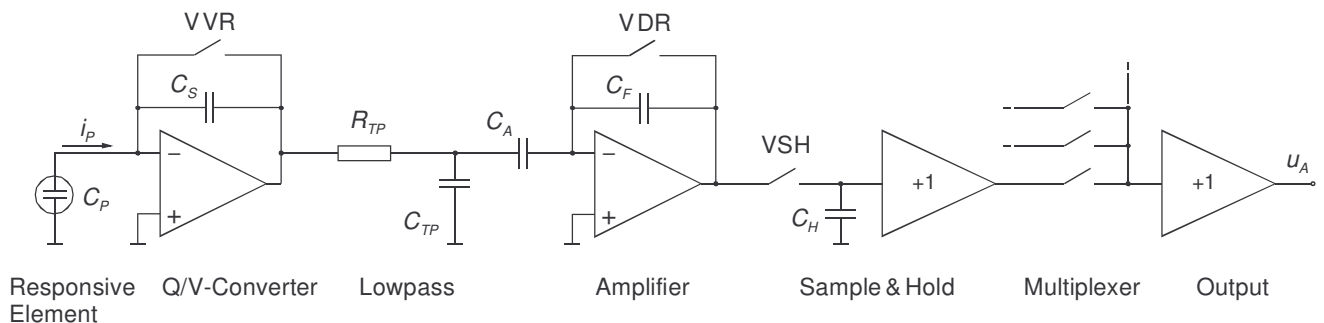

Detector geometry and optical specification

Package and pins

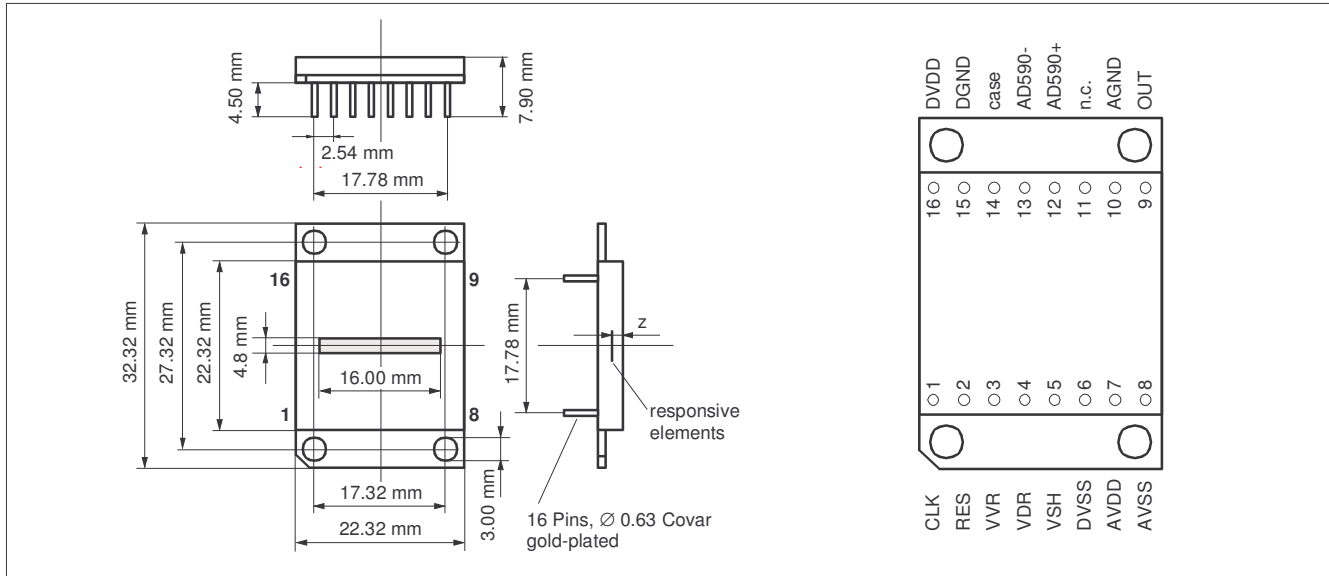

Pins

Pin number	Pin name	Remark
1	CLK	Input clock CLK
2	RES	Input clock RES
3	VVR	Input clock VVR
4	VDR	Input clock VDR
5	VSH	Input clock VSH
6	DVSS	Digital operating voltage DVSS (-5 V)
7	AVDD	Analog operating voltage AVDD (+5 V)
8	AVSS	Analog operating voltage AVSS (-5 V)
9	OUT	Analog signal output
10	AGND	Analog ground
11	n. c.	not connected
12	AD590+	Temperature sensor
13	AD590-	Temperature sensor
14	case	Case
15	DGND	Digital ground
16	DVDD	Digital operating voltage DVDD (+5 V)

Optical Specification

Geometry

Parameter	Minimum value	Typical value	Maximum value	Unit
Field of view of each pixel ¹	90			°
Pixel width		90		µm
Pitch		100		µm
Pixel length		500		µm
Distance x	4.71	4.76	4.81	mm
Distance y	11.06	11.16	11.26	mm
Distance z	1.00	1.05	1.10	mm

¹ Perpendicular to the array

Position of the Pixels

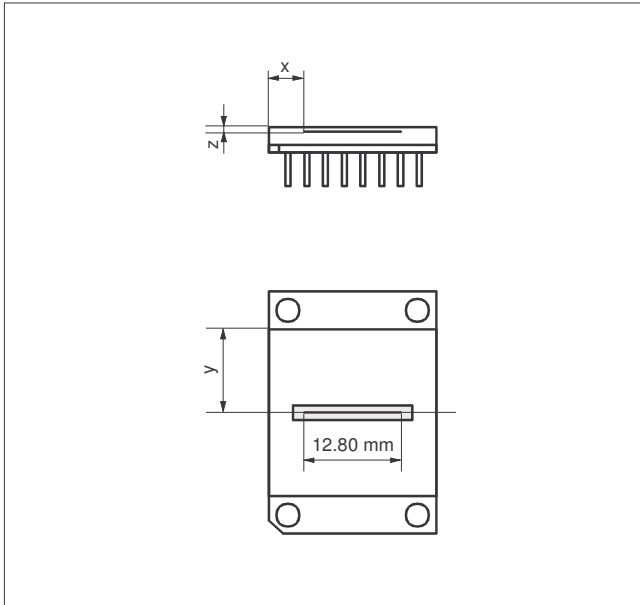

Transmission of the germanium window

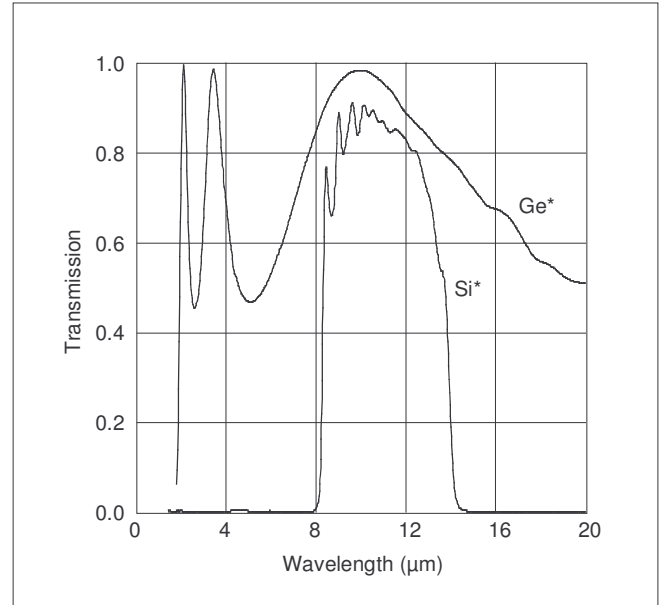

Electro-optical specification

Rectangular chopping with 128 Hz, array temperature 25 °C

Parameter	Minimum value	Typical value	Maximum value	Unit
Responsivity S_V	140000	200000		V/W
Noise U_N		1.5	3	mV
NEP		7	15	nW
MTF ($R = 3$ lp/mm)	0.4	0.6		
Uniformity ¹ S_V		1	3	%
Operating temperature	-15		70	°C

¹ No defective elements

Typical responsivity

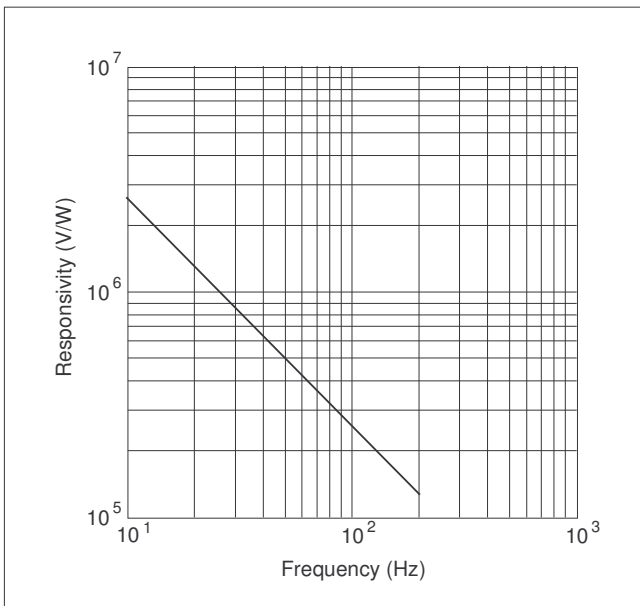

Typical MTF

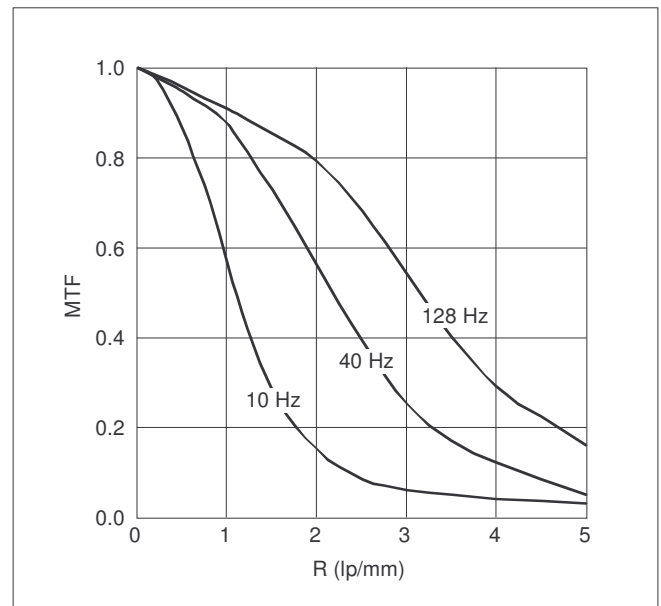

Electrical parameters

All values for DVDD = AVDD = 5 V, AVSS = DVSS = -5 V

Parameter	Minimum value	Typical value	Maximum value	Unit
AVDD, DVDD ¹	4.75	5.0	5.25	V
AVSS, DVSS ¹	-5.25	-5.0	-4.75	V
Digital inputs				
Low voltage	0		0.3 DVDD	V
High voltage	0.7 DVDD		DVDD	V
Switching threshold		0.5 DVDD		V
Leakage current			±1	μA
Current consumption I_{analog}		8		mA
Current consumption $I_{digital}$		30		μA
AD590 Operating voltage ²	+4		+30	V

¹ AVDD and DVDD; AVSS and DVSS must be connect together direct at the detector, ² See data sheet of Analog Devices

Maximum/minimum conditions

All voltages refer to ground (pin 15)

Parameter	Maximum/minimum value	Unit
DVDD, AVDD	-0.3 to +7	V
AVSS, DVSS	+0.3 to -7	V
Digital inputs CLK, RES, VVR, VDR, VSH	-0.3 to DVDD +0.3	V
Chopping frequency f_{Ch}	10 to 300	Hz
AD590+ to AD590- ¹	-20 to +44	V
Analog output ²	±5	mA
Maximum irradiance	50	mW/mm ²
Soldering temperature (10 s)	300	°C
Storage temperature	-20 to 80	°C

¹ Potential free to ground (Pin 15), ² Not short resistant

Clock parameters

All values for DVDD = AVDD = 5 V, AVSS = DVSS = -5 V

Parameter	Minimum value	Typical value	Maximum value	Unit
Chopping frequency ¹ f_{Ch}	10	128	200	Hz
Ground clock ¹ CLK f_{clk}	0	34.3	100	kHz
Reset clock high-impulse duration t_{res}	2.5	4		μs
Clock VVR high-impulse duration t_{VVR}	10	15		μs
Clock VDR high-impulse duration t_{VDR}	200	300		μs
Clock VSH low-impulse duration t_{SH}	10	15		μs
Settling time at the output t_{out}	3	5		μs
Setup time before clock t_{128SH}	10			μs
Time distance t_{SHres}	10			μs
Time distance t_{SHVVR}	10			μs
Time distance t_{SHfCh}	0			μs
Time distance t_{fChres}	0			μs
Time distance t_{clkres}	0			μs
Time distance t_{resclk}	1			μs
Time distance t_{resout}	$1.5 t_{clk} + t_{resclk}$			μs
Time distance t_{DRVR}	0			μs
Time distance t_{VRDR}	0			μs

¹ $t_{Ch low} = t_{Ch high}$

Clock diagram

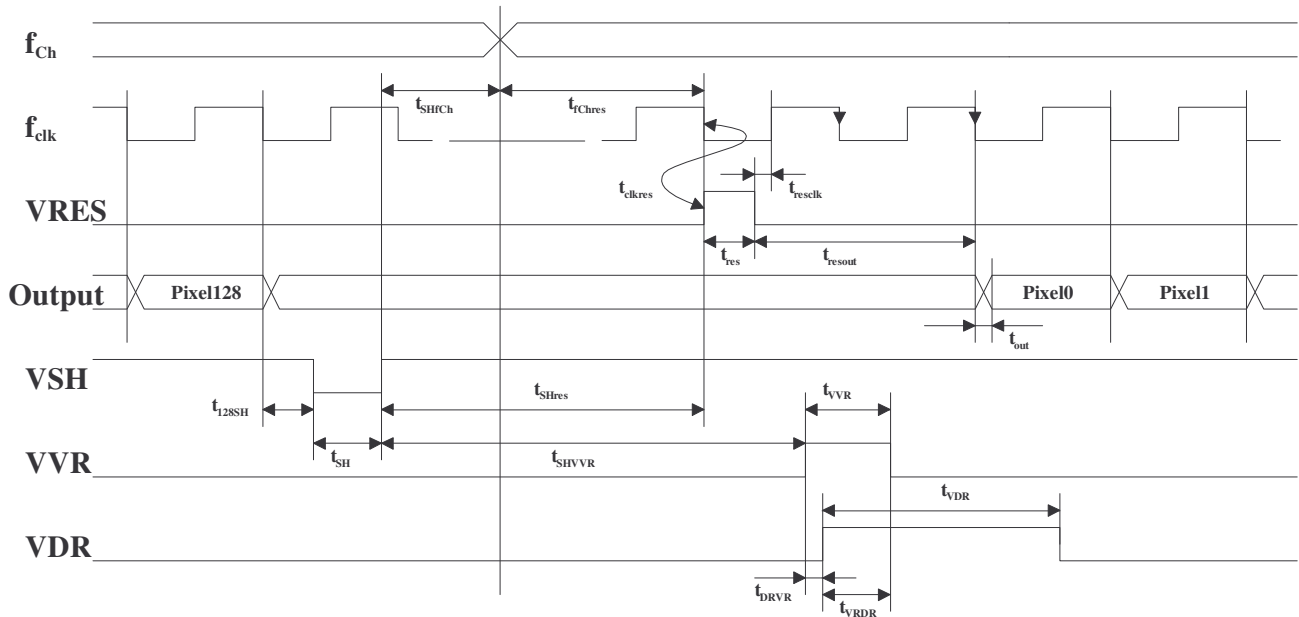

Remark: pixel 0 is an input without responsive element (dark signal)

Application remarks

Typical clock regime

Parameter	Relative value	Typical value	Unit
Chopping frequency f_{Ch}		128	Hz
Ground clock f_{clk}	$1/t_{clk}$	34 304	Hz
Reset clock high-impulse duration t_{res}	$1/4 t_{clk}$	7.3	μs
Clock VVR high-impulse duration t_{VVR}	$3 t_{clk}$	29.2	μs
Clock VDR high-impulse duration t_{VDR}	$10 t_{clk}$	292	μs
Clock VSH low-impulse duration t_{SH}	$1/2 t_{clk}$	14.6	μs

Clock diagram

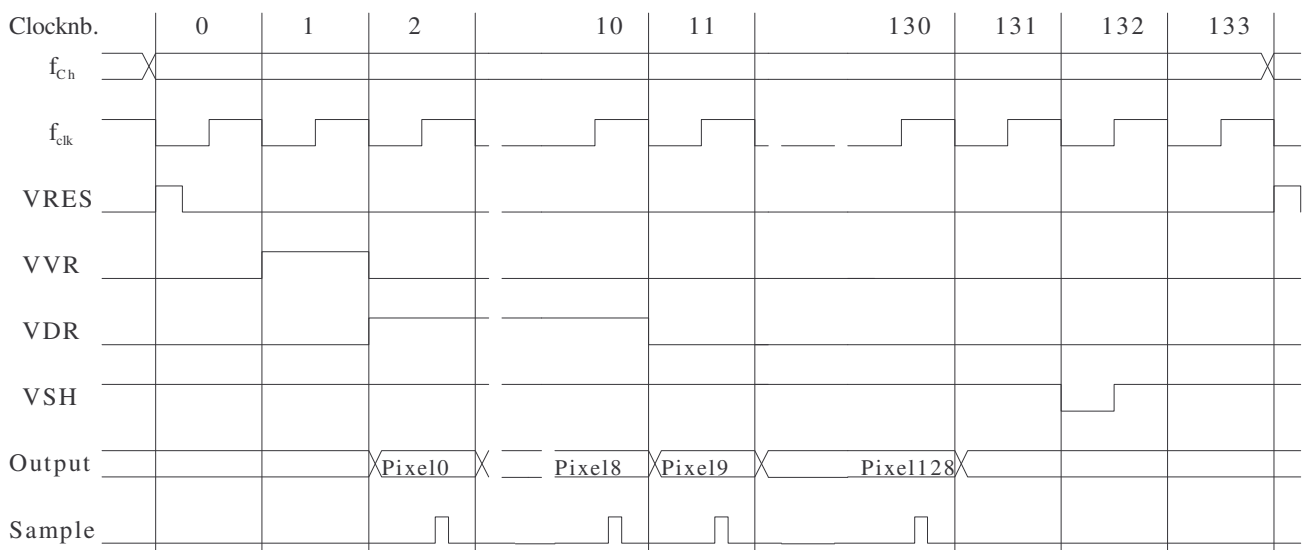

Remark: Clock 133 is for the compensation of jitter of the chopping frequency during the mechanical chopping