

## 1 Features and Benefits

- Small size single die, low cost 16x4 pixels IR array
- Easy to integrate
- Industry standard four lead TO-39 package
- Factory calibrated. Pixel to pixel relative error below 1.5%
- NETD (Noise Equivalent Temperature Difference) <0.5K@1Hz refresh rate
- I<sup>2</sup>C compatible digital interface
- Programmable refresh rate 0.5Hz...512Hz (averaging recommend frame rate 32Hz)
- 3V typical supply voltage
- Current consumption less than 7mA
- Measurement start trigger for synchronization with external control unit
- Different package options for applications and measurements versatility
- Ta -40 to 85 degC
- To -50 to 1000 degC possible; depending on accuracy requirement

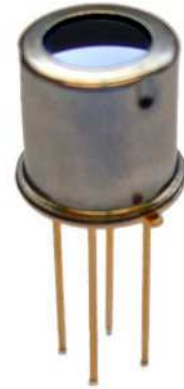

## 2 General Description

The HTPA 16x4 is a (16x4 pixels) fully calibrated IR array in industry standard four lead TO-39 package. It contains 2 chips in one package: the HTPA 16x4 (IR array plus electronics) and the 24AA02 (256x8 EEPROM)

The HTPA 16x4 contains 64 IR pixels with dedicated low noise chopper stabilized amplifier and fast ADC integrated. A PTAT (Proportional To Absolute Temperature) sensor is integrated to measure the ambient temperature of the chip. The outputs of both IR and PTAT sensors are stored in internal RAM and are accessible through I<sup>2</sup>C.

The results of the infrared sensor measurements are stored in RAM:

- 16-bit result of IR measurement for each individual sensor (64 words)
- 16-bit result of PTAT sensor

Depending on the application, an external microcontroller can read the different RAM data and, based on the calibration constants, compensate the different sensitivities of each pixel to build up a thermal image, or calculate the object temperature at each pixel at the imaged scene.

These constants are accessible by the microcontroller through the I<sup>2</sup>C bus and have to be used for external post processing of the thermal data. This post processing includes:

- Ta calculation
- Pixel offset cancelling
- Pixel to pixel sensitivity difference compensation
- Object emissivity compensation
- Object temperature calculation
- Image processing and correction if necessary

The result is an image with NETD better than 0.5K at 1Hz refresh rate.

The refresh rate of the array is programmable by means of EEPROM settings or directly via I<sup>2</sup>C command. Changes of the refresh rate have a direct impact on the integration time and noise bandwidth (faster refresh rate means higher noise level). The refresh rate is programmable in the range 0,5Hz...512Hz and can be changed to achieve the desired tradeoff between speed and accuracy.

The HTPA 16x4 requires a single 3V supply ( $\pm 0,6V$ ).

The customer can choose between 3 operating modes:

- **Normal.** In this mode the device is free running under control of the internal state machine. Depending on the selected refresh rate Fps (Frame per second) the chip is constantly measuring both IR and PTAT and is refreshing the data in the RAM with specified refresh rate;
- **Step.** This mode is foreseen for synchronization with an external micro-controller. The internal state machine is halted. If the command 'StartMeas' is received via the I<sup>2</sup>C bus, a single measurement of all IR and PTAT sensors will be done, then the chip will return in wait state. When in wait state the data in RAM can be read.
- **Power saving mode.** In this mode all internal electronics will be completely shutdown and the chip will monitor the I<sup>2</sup>C. Any transmission through I<sup>2</sup>C initiated by Start condition will be detected. The internal oscillator will be powered on and the device will receive the slave address (SA). If the SA address of HTPA 16x4 is recognized (SA=0x60) the device will respond, receive and execute the command. Otherwise the chip will remain in power saving mode. The power saving mode can reduce current consumption down to 5 $\mu$ A and is excellent for battery applications.

The HTPA 16x4 is factory calibrated in wide temperature ranges:

- -40...85 °C for the ambient temperature sensor
- -70...300 °C for the object temperature.

All figures are depending on the accuracy requirement.

Each pixel of the array will measure the average temperature of all objects in its own Field Of View (called FOV).

It is very important for the application designer to understand that the accuracy of the temperature measurement is very sensitive to the thermal equilibrium isothermal conditions (there are no temperature differences across the sensor package). The accuracy of the thermometer can be influenced by temperature differences in the package induced by causes like (among others): Hot electronics behind the sensor, heaters/coolers behind or beside the sensor or by a hot/cold object very close to the sensor that not only heats the sensing element in the thermometer but also the thermometer package.

This effect is especially relevant for thermometers with a small FOV as the energy received by the sensor from the object is reduced. Therefore, Heimann Sensor has integrated the possibility to measure the internal thermal gradients and to compensate the temperature calculation for them. However, this cannot completely compensate the effect of thermal gradients. It is therefore important to avoid the causes of thermal gradients as much as possible or to shield the sensor from them.

## Directory

1	Features and Benefits .....	1
2	General Description .....	2
3	Ordering Information .....	6
4	Pin Configuration .....	6
5	Dimensional Drawings .....	7
6	Maximum Ratings .....	8
7	Operating Conditions .....	8
8	Block diagram .....	10
9	Block description.....	11
9.1	Array layout .....	11
10	Memories .....	12
10.1	RAM (Result Memory) .....	12
10.1.1	Configuraton register .....	13
10.1.2	Trimming register.....	14
10.2	EEPROM .....	15
10.3	POR.....	17
11	Communication protocol.....	17
11.1	Start / Stop condition .....	17
11.2	Device addressing .....	18
11.3	Acknowledge .....	18
11.4	EEPROM Communication .....	18
11.5	Sensor Communication .....	18
11.5.1	Measurement trigger.....	18
11.5.2	Read measurement data .....	19
12	Device modes .....	21
12.1	Normal mode.....	21
12.2	Step mode .....	21
12.3	Power saving mode .....	21
13	Integrated Sensor for gradient compensation.....	22
14	Temperature calculation flow .....	23
14.1	Initialization .....	24
15	Calculation Considerations.....	25
15.1	Calculation of absolute temperature of the die (Ta) .....	25
15.2	Example for Ta calculations .....	26
15.3	Calculation of To .....	27
15.4	Calculating VIR(I,j)_COMPENSATED .....	28
15.5	Calculating $\alpha(i,j)$ .....	29

15.6	Example for To calculations .....	30
16	Performance Graphs .....	32
16.1	Calculated Field Of View (FOV).....	32
17	Applications Information.....	33
17.1	Use of the HTPA 16x4 in I <sup>2</sup> C configuration .....	33
18	Application Comments .....	33
19	Initialization.....	34
20	Liability .....	34
21	Glossar .....	35

### 3 Ordering Information

- HTPA → Heimann thermopile array
- a x b → number of elements
- L xx → „L“ lens cap TO39 followed by focal length of lens

### 4 Pin Configuration

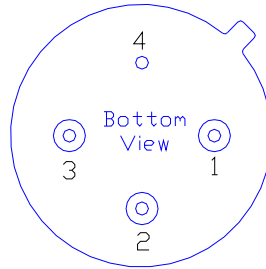

Figure 1: pin-allocation

Pin	Symbol	Description
1	SCL	Digital input, serial clock in SMBus compatible mode
2	SDA	Digital I/O, data input /output in SMBus compatible mode (open drain)
3	VDD	Positive supply voltage
4	VSS	Negative supply voltage / Ground (0V) (connected to housing)

## 5 Dimensional Drawings

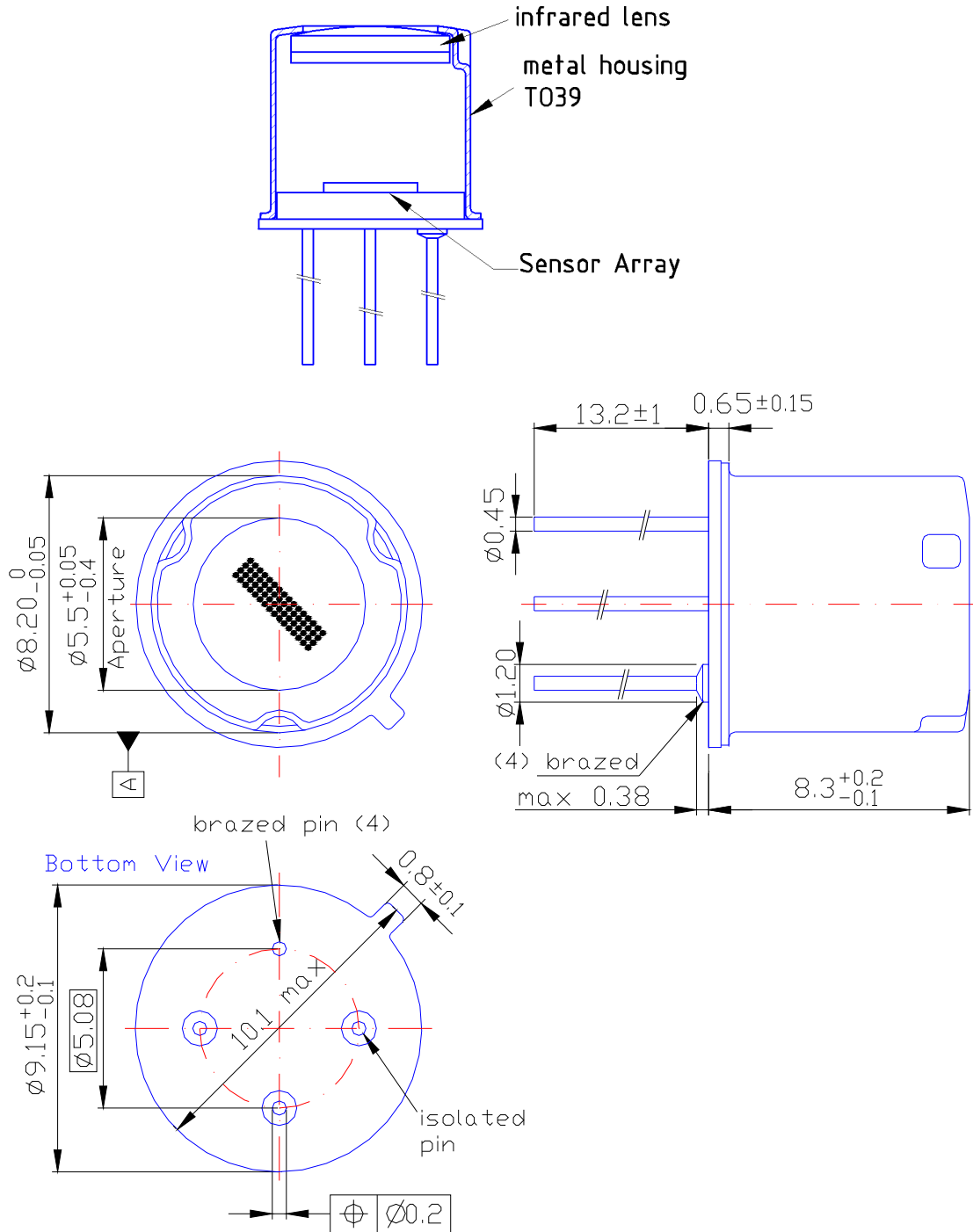

figure 2: dimensional drawing

**HEIMANN Sensor GmbH**  
 Grenzstr. 22  
 D-01109 Dresden, Germany

**Contact / Customer Support**  
 Phone 49 (0) 6123 60 50 30  
 Fax 49 (0) 6123 60 50 39

**Internet**  
[www.heimannsensor.com](http://www.heimannsensor.com)  
 e-mail: info@heimannsensor.com

## 6 Maximum Ratings

Tab 1: maximum ratings and values

Parameter	HTPA 16x4
Supply Voltage, VDD (over voltage)	5V
Supply Voltage, VDD (operating)	3.6V
Reverse Voltage (each pin)	-0.3 V
Operating Temperature Range, TA	-40...+85°C
Storage Temperature Range, TS	-40...+125°C
ESD Sensitivity (AEC Q100 002)	2kV (4kV)
DC sink current, SDA	25 mA
DC source current, SDA	NA
DC clamp current, SDA	NA
DC source current, SCL	NA (input only)
DC clamp current, SCL	NA

Exceeding the absolute maximum ratings may cause permanent damage. Exposure to absolute-maximum-rated conditions for extended periods may affect device reliability.

## 7 Operating Conditions

All parameters are preliminary for  $T_A = 25^\circ\text{C}$ ,  $V_{DD} = 3\text{V}$  (unless otherwise specified)

Tab 2: operating conditions

Parameter	Symbol	Test Conditions	Min	Typ	Max	Units
<b>Supplies</b>						
External supply	$V_{DD}$		2.4	3	3.6	V
Supply current	$I_{DD}$	No load		3.5	5	mA
Supply current (programming)	$I_{DDpr}$	No load, erase/write EEPROM operations		not specified	not specified	mA
<b>Power On Reset</b>						
POR level	$V_{POR\_up}$	Power-up (full temp range)	2	2.2	2.4	V
POR level	$V_{POR\_down}$	Power-down (full temp)	1.9	2.1	2.3	V
POR hysteresis	$V_{POR\_hys}$	Full temp range		0.1		V
$V_{DD}$ rise time (10% to 90% of specified supply)	$T_{POR}$	Ensure POR signal	100			$\mu\text{s}$
<b>I<sup>2</sup>C compatible 2-wire interface<sup>2</sup></b>						
Input high voltage	$V_{IH}$ (Ta, V)	Over temperature and supply	0.7V			V
Input low voltage	$V_{IL}$ (Ta, V)	Over temperature and supply			0.3VD	V
Output low voltage	$V_{OL}$	SDA over temperature and supply, Isink = 6mA (FM)			0.6	V
Output low voltage	$V_{OL}$	SDA over temperature and supply, Isink = 20mA (FM+)			0.4	V

SCL leakage	$I_{SCL, leak}$	$V_{SCL}=4V, Ta=+85^{\circ}C$			10	$\mu A$
SDA leakage	$I_{SDA, leak}$	$V_{SDA}=4V, Ta=+85^{\circ}C$			10	$\mu A$
SCL capacitance	$C_{SCL}$				10	pF
Slave address	SA	Factory default		60		hex
Clock frequency	$SCL_{IR}$				1	MHz
Acknowledge setup time	$T_{suac}(MD)$	8-th SCL falling edge, Master			0.45	$\mu s$
Acknowledge hold time	$T_{hdac}(MD)$	9-th SCL falling edge, Master			0.45	$\mu s$
Acknowledge setup time	$T_{suac}(SD)$	8-th SCL falling edge, Slave			0.45	$\mu s$
Acknowledge hold time	$T_{hdac}(SD)$	9-th SCL falling edge, Slave			0.45	$\mu s$
<b>EEPROM</b>						
Slave address	SA	Factory default		50		hex
Clock frequency	$SCL_{EEPROM}$				400	kHz
Data retention		$Ta = +85^{\circ}C$	200			years
Erase/write cycles		$Ta = +25^{\circ}C$	1M			Times
Erase/write cycles		$Ta = +125^{\circ}C$	100K			Times
Erase cell time	$T_{erase}$				5	ms
Write cell time	$T_{write}$				5	ms

## 8 Block diagram

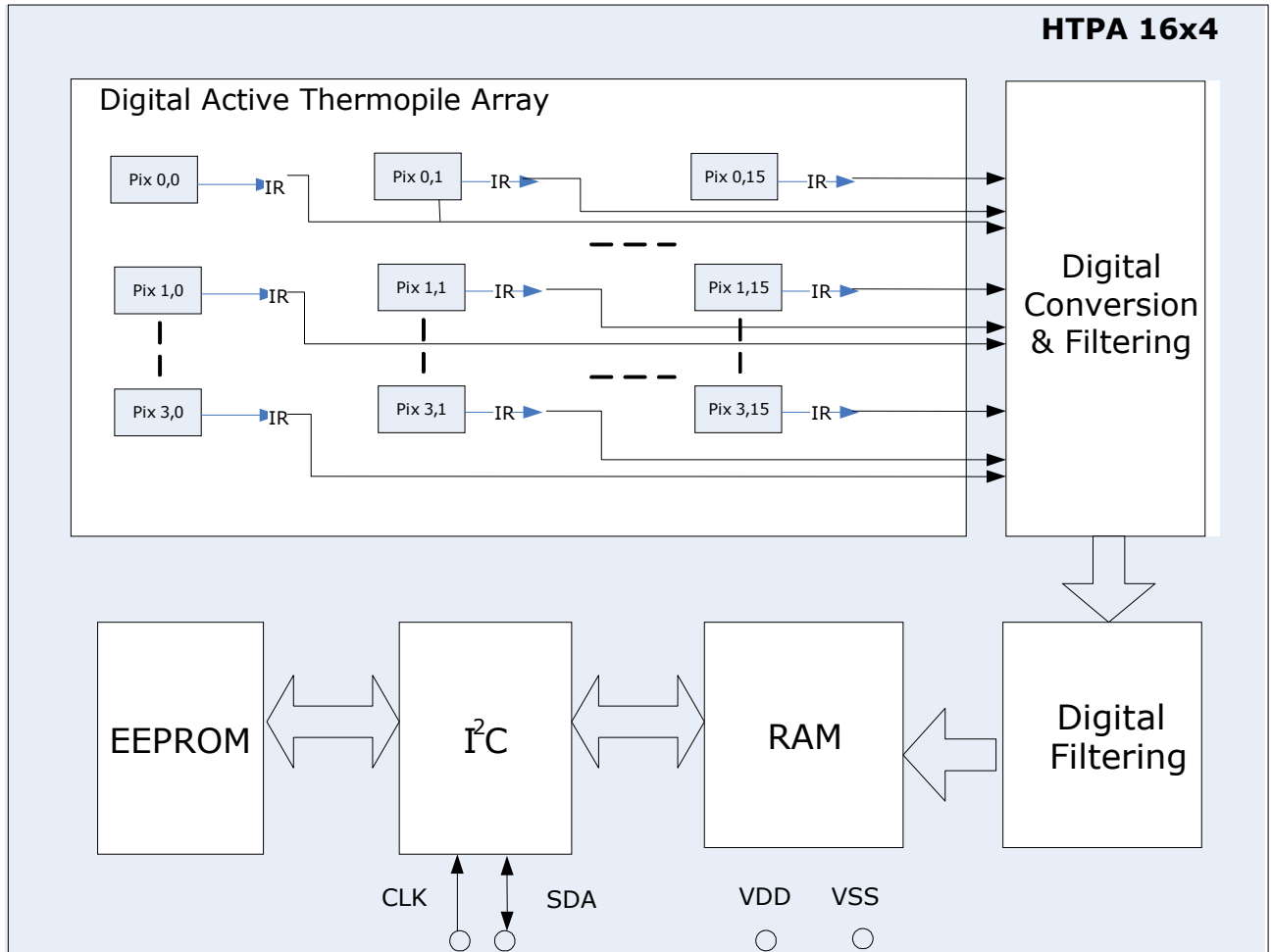

Figure 3: block diagram

The device consists of 2 chips packed in single TO-39 package

- IR array and processing electronics
- EEPROM chip

## 9 Block description

### 9.1 Array layout

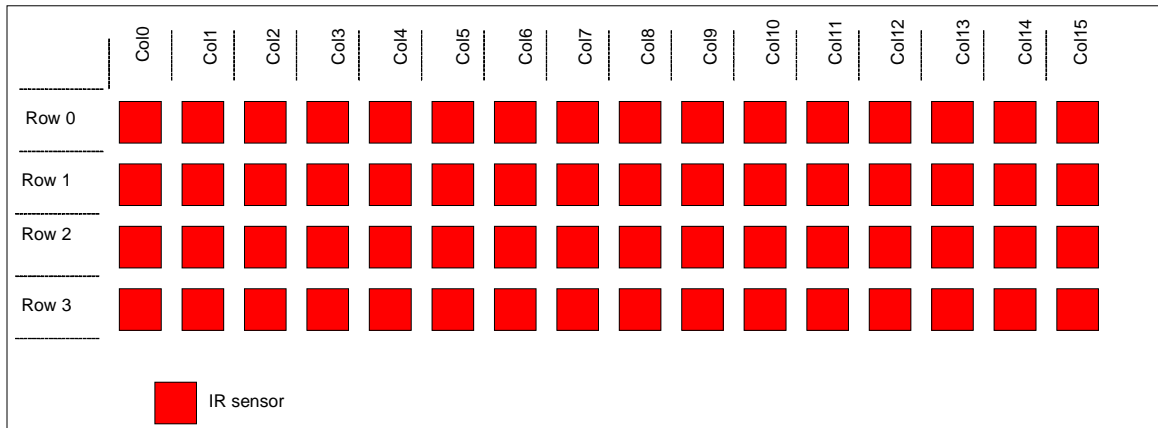

Figure 4: array layout of IR sensors and Ta-Sensors

The array consists of 64 IR sensors (called also pixels). Each pixel is identified with its row and column position as  $Pix(i,j)$  where  $i$  is its row number and  $j$  is its column number (from 0 to 15).

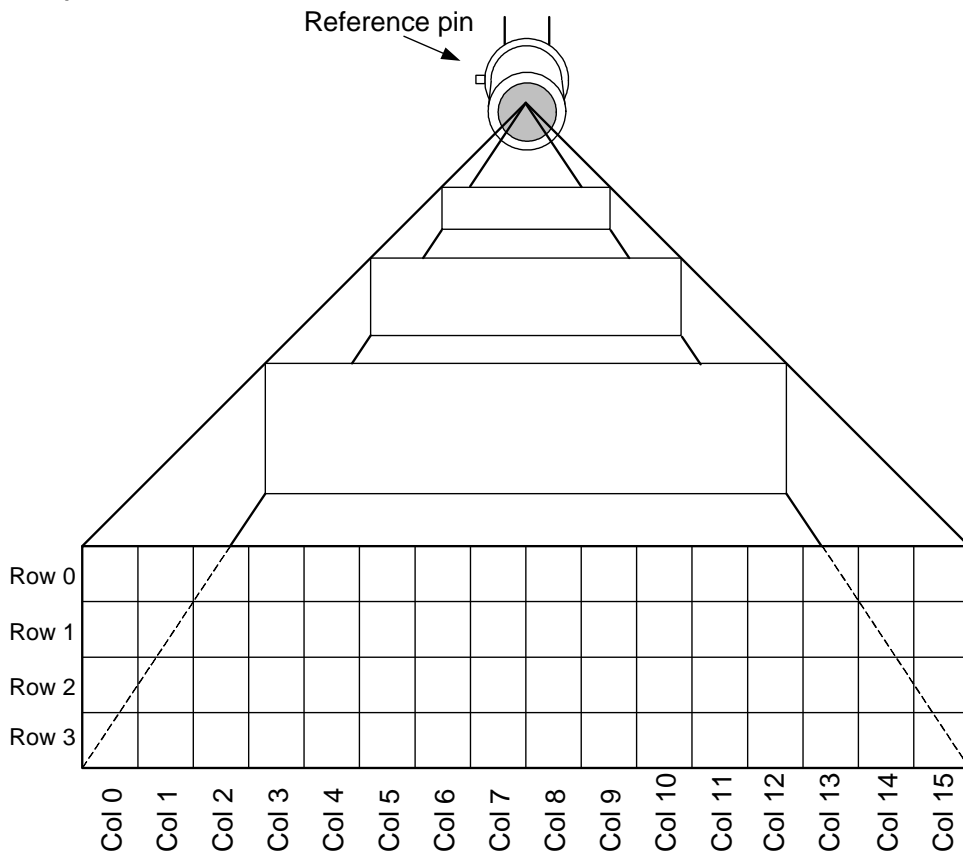

Figure 5: assignment from inside alignment to external reference pin

## 10 Memories

### 10.1 RAM (Result Memory)

The on chip 146x16 RAM is accessible for reading via I<sup>2</sup>C. The RAM is used for storing the results of measurements of pixels and Ta sensor and is distributed as follows:

- 64 words for IR sensors. The data will be in 2's complement format
- 1 word for measurement result of PTAT sensor. This sensor is selected to be a reference Ta for the device. The temperatures of all other Ta sensors are measured relative to this one. The data is 16 bit without sign. Physically this sensor is placed close to Ta(1,1).

Tab. 3: RAM map

Address	RAM variable description
0x00	IR sensor (0,0) result
0x01	IR sensor (1,0) result
0x02	IR sensor (2,0) result
0x03	IR sensor (3,0) result
0x04	IR sensor (0,1) result
0x05	IR sensor (1,1) result
0x06	IR sensor (2,1) result
0x07	IR sensor (3,1) result
...	...
0x3C	IR sensor (0,15) result
0x3D	IR sensor (1,15) result
0x3E	IR sensor (2,15) result
0x3F	IR sensor (3,15) result
0x90	PTAT sensor result
0x91	Compensation sensor result
0x92	Configuration register
0x93	Trimming register

### 10.1.1 Configuraton register

The configuration register defines the chip operating modes.  
 It can be read and written by the I<sup>2</sup>C MD.

Tab. 4: configuration register map

15	14	13	12	11	10	9	8	7	6	5	4	3	2	1	0	configuration register bit meaning (0x92)
												0	0	0	0	- IR Refresh rate = 512Hz - <b>(default)</b>
												0	0	0	1	- IR Refresh rate = 512Hz
												0	0	1	0	- IR Refresh rate = 512Hz
												0	0	1	1	- IR Refresh rate = 512Hz
												0	1	0	0	- IR Refresh rate = 512Hz
												0	1	0	1	- IR Refresh rate = 512Hz
												0	1	1	0	- IR Refresh rate = 256Hz
												0	1	1	1	- IR Refresh rate = 128Hz
												1	0	0	0	- IR Refresh rate = 64Hz
												1	0	0	1	- IR Refresh rate = 32Hz
												1	0	1	0	- IR Refresh rate = 16Hz
												1	0	1	1	- IR Refresh rate = 8Hz
												1	1	0	0	- IR Refresh rate = 4Hz
												1	1	0	1	- IR Refresh rate = 2Hz
												1	1	1	0	- IR Refresh rate = 1Hz
												1	1	1	1	- IR Refresh rate = 0.5Hz
										X	X	NA				
									0							- continuous measurement mode - <b>(default)</b>
									1							- step measurement mode
								0								- Normal operation mode
								1								- sleep mode - <b>(default)</b>
								0								- No Ta measurement running (Flag only, cannot be written) - <b>(default)</b>
								1								- Ta measurement running (Flag only, cannot be written)
								0								- No IR measurement running (Flag only, cannot be written)
								1								- IR measurement running (Flag only, cannot be written) - <b>(default)</b>
								0								- POR or Brown out occurred - Need to reload configuration register
								1								- MD must wright "1" during uploading configuration register - <b>(default)</b>
								0								- I2C FM + mode enabled (max bit transfer rates up to 1000kbits/s) - <b>(default)</b>
								1								- I2C FM + mode disabled (max bit transfer rates up to 400kbits/s)
								0	0							- Ta refresh rate = 4Hz - <b>(default)</b>
								0	1							- Ta refresh rate = 2Hz
								1	0							- Ta refresh rate = 1Hz
								1	1							- Ta refresh rate = 0.5Hz
								0								- ADC high reference enabled - <b>(default)</b>
								1								- ADC low reference enabled
x																NA

Please note, that the default values should be configured by the user before using the HTPA 16x4 the first time.

### 10.1.2 Trimming register

Tab. 5: trimming register

15	14	13	12	11	10	9	8	7	6	5	4	3	2	1	0	Trimming register bit meaning (0x93)
									7 bit value							- Oscillator trim value
x	x	x	x	x	x	x	x	x	x	NA						

Opcode – 0x04.

This command is used to set the trimming parameters – oscillator, bandgap, current source trimming bits values. It can be read and written by the I<sup>2</sup>C MD.

Simple data check is introduced. The two data bytes are sent two times: first time with the true data minus 0xAA and second time – the true data. The chip does the addition with 0xAA internally and checks the second received byte. Only if the addition results match with the received data for the two bytes, the configuration register is updated. The command communication is illustrated below:

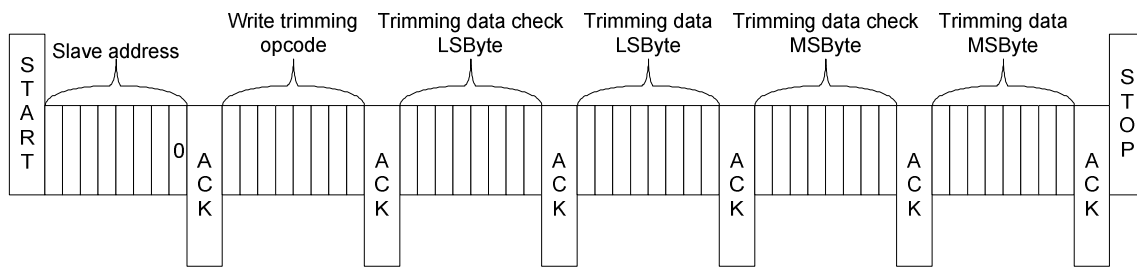

## 10.2 EEPROM

A 2kbit, organized as 256x8 EEPROM is built in the HTPA 16x4. The EEPROM is on a separate die (separate SA = 0x50) and is used to store the calibration constants and the configuration of the device.

Tab. 6: EEPROM map

Address	0	1	2	3	4	5	6	7
00	ai(0,0)	ai(1,0)	ai(2,0)	ai(3,0)	ai(0,1)	ai(1,1)	ai(2,1)	ai(3,1)
08	ai - IR pixels individual offset coefficients							
10								
18								
20								
28								
30								
38	ai(0,14)	ai(1,14)	ai(2,14)	ai(3,14)	ai(1,15)	ai(2,15)	ai(3,15)	
40	bi(0,0)	bi(1,0)	bi(2,0)	bi(3,0)	bi(0,1)	bi(1,1)	bi(2,1)	bi(3,1)
48	bi - Individual Ta dependence (slope) of IR pixels offset							
50								
58								
60								
68								
70								
78	bi(0,14)	bi(1,14)	bi(2,14)	bi(3,14)	bi(1,15)	bi(2,15)	bi(3,15)	
80	$\Delta\alpha(0,0)$	$\Delta\alpha(1,0)$	$\Delta\alpha(2,0)$	$\Delta\alpha(3,0)$	$\Delta\alpha(0,1)$	$\Delta\alpha(1,1)$	$\Delta\alpha(2,1)$	$\Delta\alpha(3,1)$
88	Individual sensitivity coefficients							
90								
98								
A0								
A8								
B0								
B8	$\Delta\alpha(0,14)$	$\Delta\alpha(1,14)$	$\Delta\alpha(2,14)$	$\Delta\alpha(3,14)$	$\Delta\alpha(0,15)$	$\Delta\alpha(1,15)$	$\Delta\alpha(2,15)$	$\Delta\alpha(3,15)$
C0	Heimann Sensor reserved							
C8								
D0								
D8	TGC	Scale offset	PTAT					
E0	common sensitivity coefficients				Emissivity			
E8	Heimann Sensor reserved							
F0							Config register	OSC trim
F8	Chip ID							

Detailed descriptions of some EEPROM addresses are depicted here after:

**HEIMANN Sensor GmbH**  
 Grenzstr. 22  
 D-01109 Dresden, Germany

**Contact / Customer Support**  
 Phone 49 (0) 6123 60 50 30  
 Fax 49 (0) 6123 60 50 39

**Internet**  
[www.heimannsensor.com](http://www.heimannsensor.com)  
 e-mail: info@heimannsensor.com

Tab. 7: D7...D0 EEPROM cell meaning – Compensation pixel constants

D7	D6	D5	D4	D3	D2	D1	D0	EEPROM cell meaning
Heimann Sensor reserved								
acp - Compensation pixel individual offset								
bcp - Individual Ta dependence (slope) of the compensation pixel offset								
$\Delta\alpha_{cp\_L}$ $\Delta\alpha_{cp\_L}$ - Sensitivity coefficient of the compensation pixel								

Tab. 8: DF...D8 EEPROM cell meaning – PTAT constants

DF	DE	DD	DC	DB	DA	D9	D8	EEPROM cell meaning
TGC - Thermal Gradient Coefficient								
$b_{i\_scale}$ - Scaling Coefficient of slope of IR pixel offset								
$V_{th\_H}$ $V_{th\_L}$ - Vth0 of absolute temperature sensor								
KT1_H KT1_L - KT1 of absolute temperature sensor								
KT2_H KT2_L - KT2 of absolute temperature sensor								

Tab. 9: E7...E0 EEPROM cell meaning

E7	E6	E5	E4	E3	E2	E1	E0	EEPROM cell meaning
$\alpha_{0\_H}$ $\alpha_{0\_L}$ - Common sensitivity coefficient								
$\alpha_{0\_scale}$ - Common sensitivity coefficient								
$\Delta\alpha_{scale}$ - Individual sensitivity scaling coefficient								
$\epsilon\_H$ $\epsilon\_L$ - Emissivity coefficient								
Heimann Sensor reserved								

Tab. 10: F7...F0 EEPROM cell meaning

F7	F6	F5	F4	F3	F2	F1	F0	EEPROM cell meaning
Heimann Sensor reserved								
CFG_H CFG_L - Config register value								
OSC_trim - Oscillator trimming value								

## 10.3 POR

The Power On Reset (POR) is connected to the Vdd supply. The on-chip POR circuit provides an active level of the POR signal when the Vdd voltage rises above approximately 0.5V and holds the entire HTPA 16x4 in reset until the Vdd is higher than 2.4V. The device will start approximately 5 ms after the POR release.

## 11 Communication protocol

The device supports Fast Mode Plus I<sup>2</sup>C FM+ (up to 1Mbps) and will work in slave mode only.

See full I<sup>2</sup>C specification at: [http://www.nxp.com/documents/user\\_manual/UM10204.pdf](http://www.nxp.com/documents/user_manual/UM10204.pdf)

The communication is running through 2 digital pins: SCL and SDA. The master device is providing the clock signal SCL for the communication. The data line SDA is driven by either the master or the slave depending on the direction of the communication. A '0' is transmitted by pulling the SDA line to 'LOW' and a '1' by releasing it 'HIGH'. During the data transfer the SDA must remain stable while SCL is HIGH. Changes in SDA are allowed only when SCL is LOW.

### 11.1 Start / Stop condition

Each communication session is initiated by a START condition and ends with a STOP condition. A START condition is initiated by a HIGH to LOW transition of the SDA while a STOP is generated by a LOW to HIGH transition. Both changes must be done while the SCL is HIGH (see the figure)

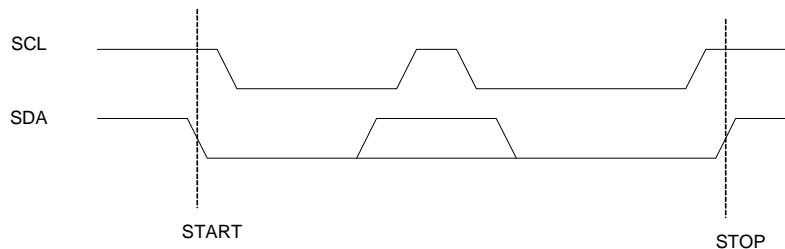

Figure 6: Start / Stop conditions of I<sup>2</sup>C

## 11.2 Device addressing

The master is addressing the slave device by sending an 7-bit slave address + R/W bit after the START condition. This bit indicates the direction of the transfer:

- Read (HIGH) means that the master will read the data from the slave
- Write (LOW) means that the master will send data to the slave

HTPA 16x4 is responding to 2 different slave addresses:

1	0	1	0	0	0	0	R/W
---	---	---	---	---	---	---	-----

for access to internal EEPROM

1	1	0	0	0	0	0	R/W
---	---	---	---	---	---	---	-----

for access to IR array chip

## 11.3 Acknowledge

During the 9<sup>th</sup> clock following every byte transfer the transmitter releases the SDA line. The receiver acknowledges (ACK) receiving the byte by pulling SDA line to low or does not acknowledge (NoACK) by letting the SDA high.

## 11.4 EEPROM Communication

For further information see datasheet of 24AA02.

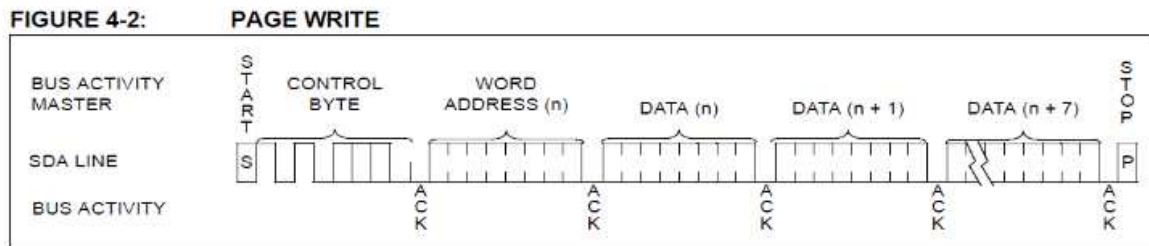

## 11.5 Sensor Communication

### 11.5.1 Measurement trigger

After the initialization procedure is done depending on the selected measurement mode (bit 6 in the configuration register) there are two possible routines:

- continuous mode
  - wait for valid data (depending on chosen refresh rates – IR and PTAT)
- Step mode
  - Send start measurement command

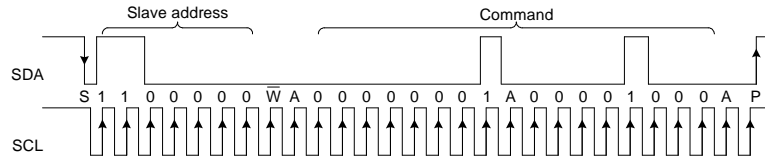

Figure 7: Start measurement command (SA = 0x60, command = 0x0801)

- Wait certain time
- Wait for the ready flag to be set

### 11.5.2 Read measurement data

#### IR data read

There are four options available for reading IR data:

- Whole frame read (Heimann Sensor recommends the whole frame read for maximum refresh rate)

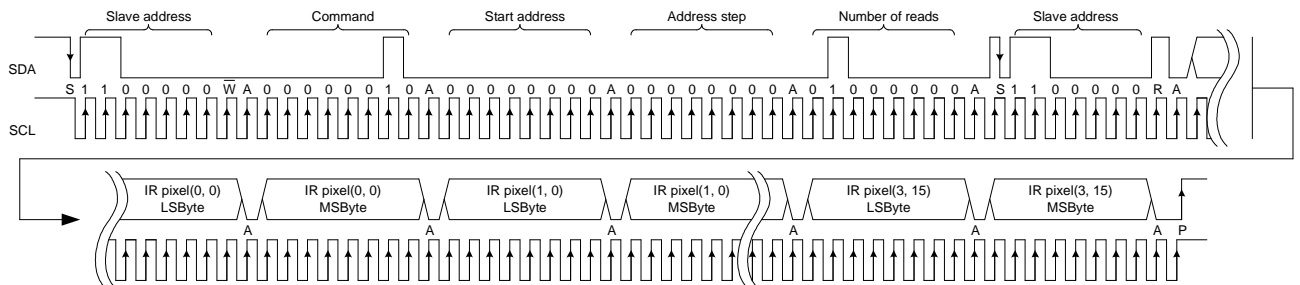

Figure 8 Whole frame (SA = 0x60, command = 0x02, Start address = 0x00, Address step = 0x01, Number of reads = 0x40) measurement result read

- Single column read

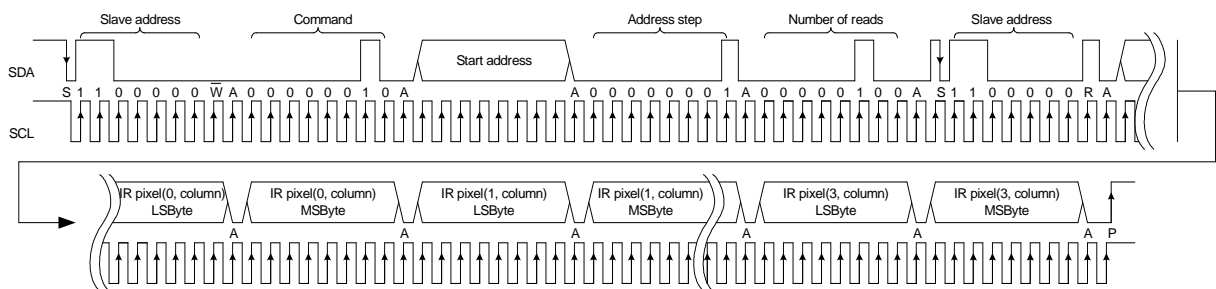

Figure 9 Single column (SA = 0x60, command = 0x02, Start address = 0x00...0x3C (step 0x04),

Address step = 0x01, Number of reads = 0x04) measurement result read

- Single line read

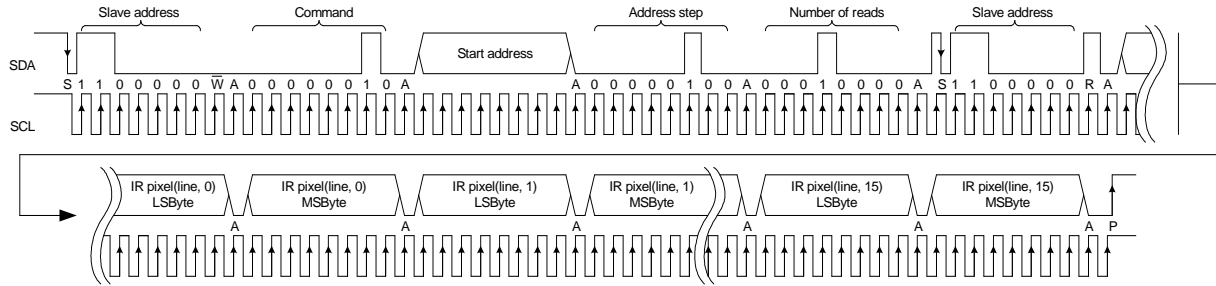

Figure 10 Single line (SA = 0x60, command = 0x02, Start address = 0x00...0x03 (step 0x01), Address step = 0x04, Number of reads = 0x10) measurement result read

- Single pixel read

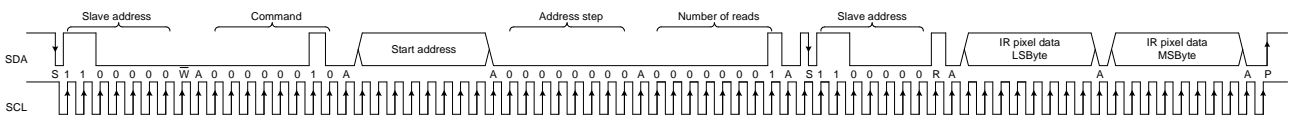

Figure 11 Single pixel (SA = 0x60, command = 0x02, Start address = 0x00...0x3F, Address step = 0x00, Number of reads = 0x01) measurement result read

**PTATdata read**

Absolute ambient temperature data of the device itself (package temperature) can be read by using following command:

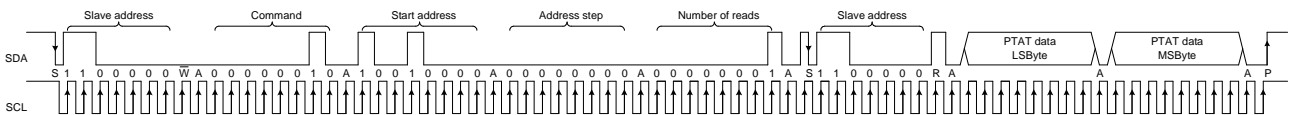

Figure 12: PTAT (SA = 0x60, command = 0x02, Start address = 0x90, Address step = 0x00, Number of reads = 0x01) measurement result read

$$PTAT\_data = \{ PTAT\_data\_MSbyte : PTAT\_data\_LSbyte \}$$

**Compensation pixel read**

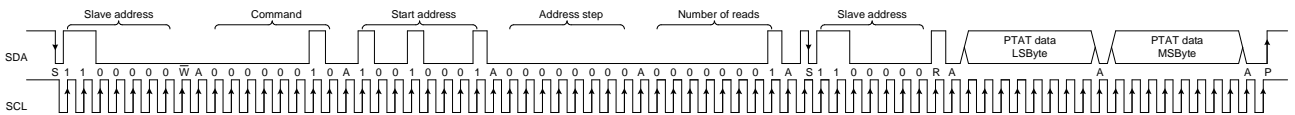

Figure 13 Compensation pixel (SA = 0x60, command = 0x02, Start address = 0x91, Address step = 0x00, Number of reads = 0x01) measurement result read

The 16bit data for each pixel is:

$$IR(i, j)\_data = \{ IR(i, j)\_data\_MSbyte : IR(i, j)\_data\_LSbyte \}$$

## 12 Device modes

The device can operate in following modes:

- Normal mode
- Step mode
- Power saving mode

### 12.1 Normal mode

In this mode the measurements are constantly running. Depending on the selected refresh rate Fps in ConfReg, the data for IR pixels and Ta will be updated in the RAM each 1/Fps seconds. In this mode the external microcontroller has full access to the internal registers and memories of the device (both for HTPA 16x4 and EEPROM chip).

### 12.2 Step mode

This mode is foreseen for single measurements triggered by the external device (microcontroller). Entering this mode is possible by writing the appropriate code in ConfReg. A measurement is triggered by sending the command StartMeas. On detecting the command, the HTPA 16x4 will start the measurements immediately after the I<sup>2</sup>C session is finished (STOP condition detected). The measurement time is 1/Fps and can be selected in 2 possible ways:

- The already programmed Fps parameter in ConfReg can be used and the measurement (integration) time will take 1/Fps
- The Fps parameter can be an argument in the StartMeas command.

Once the Step mode is initiated the access to the internal registers of the device will be disabled. If the master sends a command to the HTPA 16x4 while the measurement in step mode is ongoing, a NoAckn will be received after the slave address is transmitted.

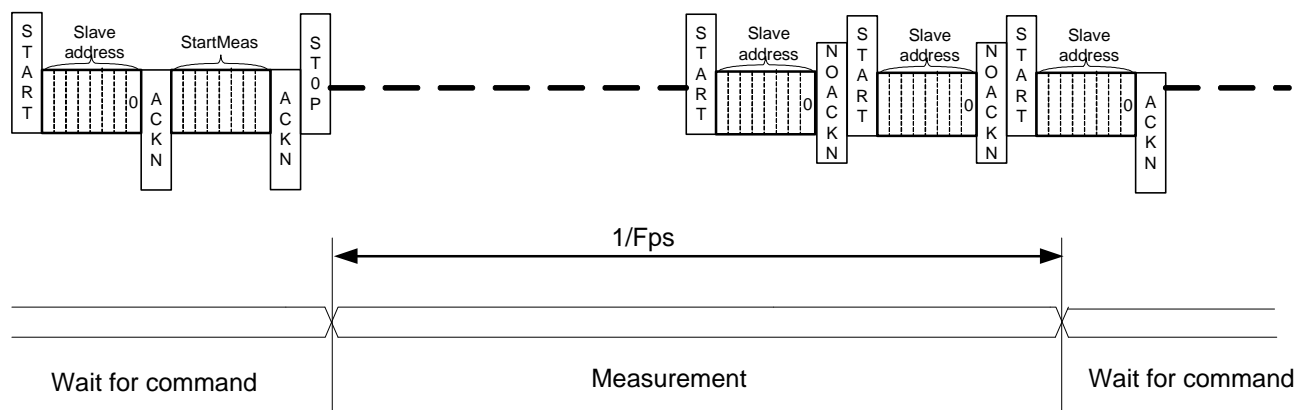

Figure 14: Execution of Start\_Meas in Step mode

### 12.3 Power saving mode

In this mode the device will be completely shutdown and the current consumption will be minimized to less than 5uA. Entering this mode is initiated by sending the command 'Sleep'. Upon receiving it the device will shutdown all electronics, including the internal oscillator. The chip will monitor the I<sup>2</sup>C line. Each START condition will wake up the

oscillator and the chip will receive and evaluate the slave address. If the address is 0x60 (address programmed in HTPA 16x4) the device will evaluate the whole command and will execute it. If not, the oscillator will be switched off again.

### **13 Integrated Sensor for gradient compensation**

The IR sensor readings and accuracy are very sensitive to any temperature gradients over the package. Any temperature difference between the cold junction of thermopile and (part of) the package, 'seen' by the IR sensor will create an error signal. Such a problem is not very severe for the applications where absolute measurement is not required, because in this case it is important to cancel the distortion.

However for the applications where the picture must be converted to temperatures, seen by the different pixels, such a gradient will introduce huge error in the measurement. The problem will be even more severe if there is a variation of the gradient (unfortunately the most common case, because the gradient comes from power dissipation of electronics on the same pcb, which varies with environmental conditions).

The HTPA16x4 supports one extra IR channel containing amplifier, ADC and digital filter. The input of this chain is connected to bond pads. An additional IR sensor can be placed in the same package and connected to these bond pads. If this sensor is optically 'blinded' (seeing only package, not outside) its output can be used to compensate the error readings of the main array.

Heimann Sensor has developed and implemented this approach successfully. The experience shows that the readings of additional sensor allow reduction of the gradient's error by factor of 10.

### 14 Temperature calculation flow

The following algorithm shows an example of a program execution flow to achieve object as well as ambient temperatures.

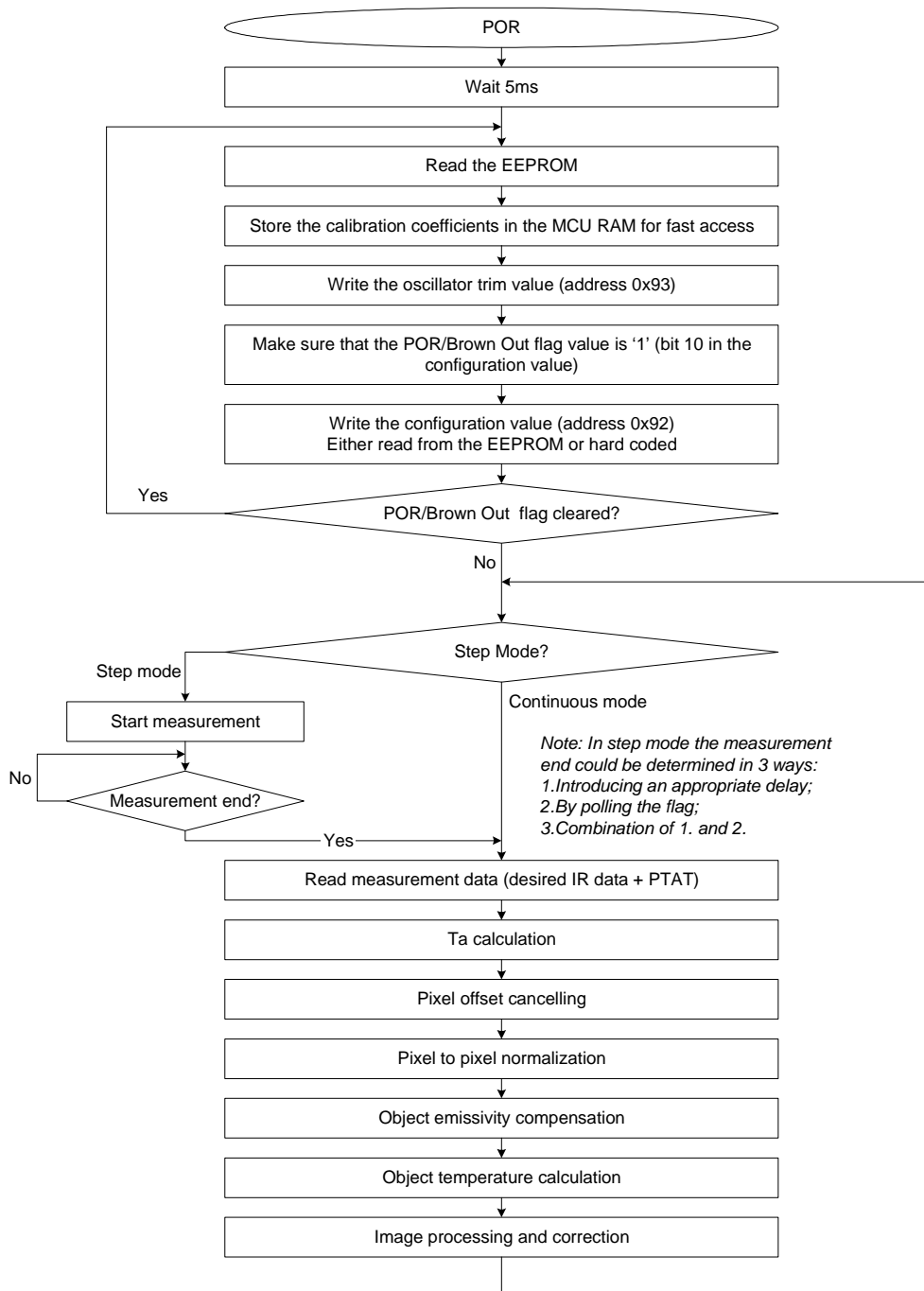

Figure 15: temperature calculation flow

## 14.1 Initialization

After the POR is released the external CPU must execute an initialization procedure. This procedure must start at least 5ms after POR release.

- Read the whole EEPROM (see Figure 16). For maximum speed performance Heimann Sensor recommends that the whole calibration data is stored into the client MCU RAM. However it is possible to read the calibration data from the EEPROM only when needed. This will result in increased time for temperature calculation i.e. low refresh rate.

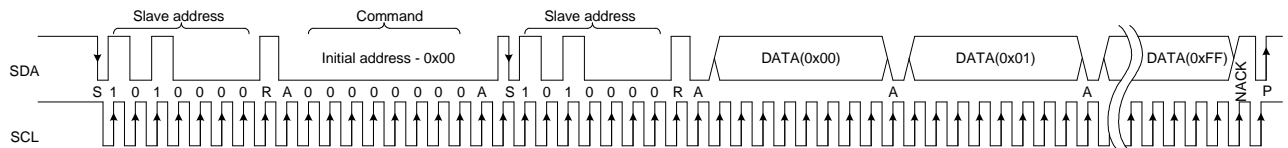

Figure 16 Whole EEPROM dump (SA = 0x50)

- Store the EEPROM content into customer MCU RAM (see above paragraph for optional information)
- Write the oscillator trimming value (extracted from EEPROM content at address 0xF7) into the corresponding register (0x93).

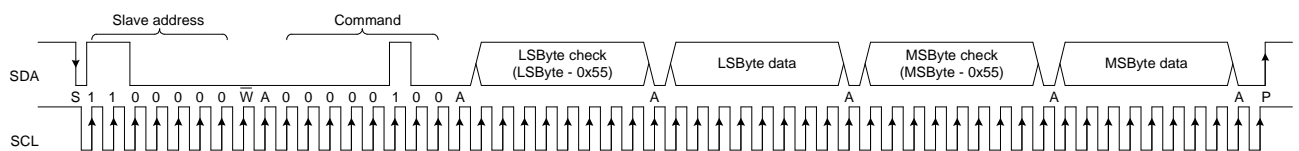

Figure 17 Write oscillator trimming (SA = 0x60, command = 0x04)

- Write device configuration value. In EEPROM addresses (0xF5 and 0xF6) Heimann Sensor provides a typical value of the configuration register (0x740E). So it is up to the user to copy that value or hardcode a new value to be loaded into the configuration register. If the EEPROM value is to be used the 16 bits are combined as follows:

For instance if EEPROM 0xF5 = 0x0E and 0xF6 = 0x74, the Configuration register value is:

$$\text{Configuration\_register\_value} = \{0xF6 : 0xF5\} = 0x740E$$

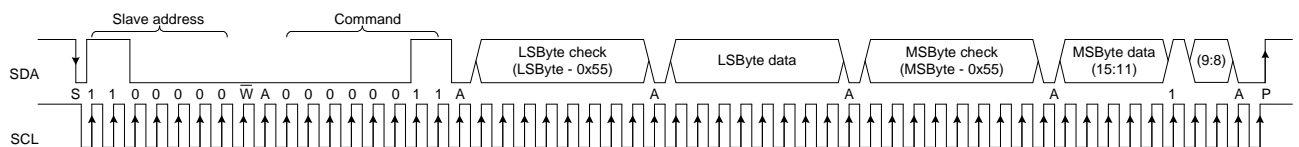

Figure 18 Write configuration register (SA = 0x60, command = 0x03)

**NOTE: The customer must ensure that the bit 10 (POR or Brown-out flag) in Configuration register is set to "1" by the MD. Furthermore this bit must be checked regularly and if it is cleared that means that the device has been reset and the initialization procedure must be redone.**

Opcode – 0x03.

This command is used to set the configuration register (16bits) value – all configuration settings.

Simple data check is introduced. The two data bytes are sent two times: first time with the true data minus 0x55 and second time – the true data. The chip does the addition with 0x55 internally and checks the second received byte. Only if the addition results match with the received data for the two bytes, the configuration register is updated.

The command communication is illustrated below:

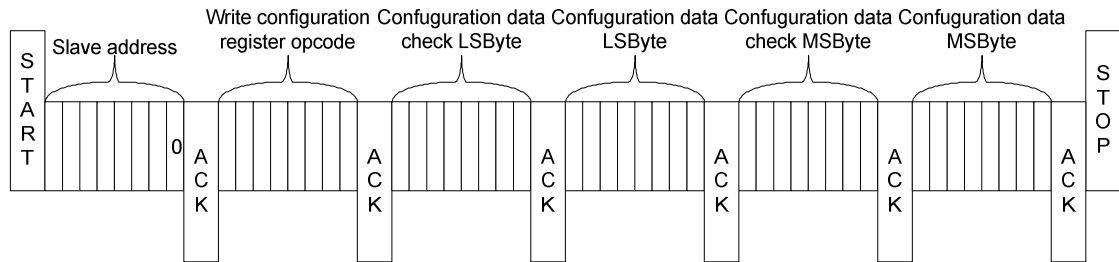

Figure 19: Write configuration register command

The default configuration is:

- IR refresh rate = 1Hz
- Ta refresh rate = 0.5Hz
- Continuous measurement mode
- Normal mode (no sleep)
- I<sup>2</sup>C FM+ mode (max bit transfer rates up to 1000 kbit/s) enabled
- ADC low reference enabled

## 15 Calculation Considerations

### 15.1 Calculation of absolute temperature of the die (Ta)

The output signal of the IR sensor is relative to its cold junction temperature. That is why we need to know the absolute temperature of the die in order to be able to calculate the object temperature 'seen' by each pixel.

The Ta can be calculated using the formula:

$$Ta = \frac{-K_{T1} + \sqrt{K_{T1}^2 - 4K_{T2}[V_{TH}(25) - PTAT\_data]}}{2K_{T2}} + 25, [^{\circ}C]$$

Constants  $V_{TH}(25)$ ,  $K_{T1}$  and  $K_{T2}$  are stored in EEPROM at following addresses as two's complement values:

Tab. 11: absolute temperature values storage adress

EEPROM address	Cell name	Stored as	Parameter
0xDA	$V_{TH\_L}$	2's complement	$V_{TH0}$ of absolute temperature sensor
0xDB	$V_{TH\_H}$		
0xDC	$K_{T1\_L}$	2's complement	$K_{T1}$ of absolute temperature sensor
0xDD	$K_{T1\_H}$		
0xDE	$K_{T2\_L}$	2's complement	$K_{T2}$ of absolute temperature sensor
0xDF	$K_{T2\_H}$		

$$V_{TH}(25) = 256.V_{TH\_H} + V_{TH\_L}$$

$$K_{T1} = \frac{256.K_{T1\_H} + K_{T1\_L}}{2^{10}}$$

$$K_{T2} = \frac{256.K_{T2\_H} + K_{T2\_L}}{2^{20}}$$

## 15.2 Example for Ta calculations

Let's assume that the values in EEPROM are as follows:

Tab. 12: examples of cell values written in the EEPROM

EEPROM address	Cell name	Cell values (hex)
0xDA	$V_{TH\_L}$	0x78
0xDB	$V_{TH\_H}$	0x1A
0xDC	$K_{T1\_L}$	0x33
0xDD	$K_{T1\_H}$	0x5B
0xDE	$K_{T2\_L}$	0xCC
0xDF	$K_{T2\_H}$	0xED

$$V_{TH}(25) = 256.V_{TH\_H} + V_{TH\_L} = 256.26 + 120 = 6776, \text{ decimal value}$$

$$\text{Sign check } 6776 < 32767 \rightarrow V_{TH}(25) = 6776$$

$$K_{T1} = \frac{256.K_{T1\_H} + K_{T1\_L}}{2^{10}} = \frac{256.91 + 51}{1024} = \frac{23347}{1024}$$

$$\text{Sign check } 23347 < 32767 \rightarrow K_{T1} = \frac{23347}{1024} \approx 22.7998$$

$$K_{T_2} = \frac{256 \cdot K_{T_2-H} + K_{T_2-L}}{2^{20}} = \frac{256 \cdot 237 + 204}{1048576} = \frac{60876}{1048576}$$

$$\text{Sign check } 60876 > 32767 \rightarrow K_{T_2} = \frac{60876 - 65536}{1048576} = \frac{-4660}{1048576} \approx -0.0044441$$

Let's assume that the input data is:

$$PTAT\_data = 0x1AC0 = 6848 \text{ dec}$$

Thus the ambient temperature is:

$$T_a = \frac{-K_{T_1} + \sqrt{K_{T_1}^2 - 4K_{T_2}[V_{TH}(25) - PTAT\_data]}}{2K_{T_2}}$$

$$T_a \approx \frac{-22.7998 + \sqrt{519.8309 - 4(-0.0044441)[6776 - 6848]}}{-0.0088882} + 25$$

$$T_a \approx \frac{-22.7998 + \sqrt{519.8309 + 0.0177764(-72)}}{-0.0088882} + 25$$

$$T_a \approx \frac{-22.7998 + \sqrt{518.551}}{-0.0088882} + 25 \approx \frac{-22.7998 + 22.7717}{-0.0088882} + 25 \approx 3.16 + 25$$

$$T_a \approx 28.16^\circ\text{C}$$

### 15.3 Calculation of $T_o$

Following formula is used to calculate the temperature seen by specific pixel in the matrix:

$$T_{O(i,j)} = \sqrt[4]{\frac{V_{IR(i,j)\_COMPENSATED}}{\alpha_{(i,j)}} + (T_a + 273.15)^4} - 273.15, [^\circ\text{C}]$$

where:

$V_{IR(i,j)\_COMPENSATED}$  is the parasitic free IR compensated signal

$\alpha_{(i,j)}$  is a individual pixel sensitivity coefficient stored in EEPROM

$T_a$  is ambient temperature calculated in 9.4.2

## 15.4 Calculating VIR(I,j)\_COMPENSATED

### 1. Offset compensation

$$V_{IR(i,j)\_OFF\_COMP} = V_{IR(i,j)} - \left( ai_{(i,j)} + \frac{bi_{(i,j)}}{2^{b_{i\_scale}}} (T_a - T_{a\_0}) \right)$$

Where:

$V_{IR(i,j)}$  is a individual pixel IR\_data readout (RAM read)

$ai_{(i,j)}$  is a individual pixel offset stored in EEPROM as two's complement value

$bi_{(i,j)}$  is a Individual Ta dependence (slope) of IR pixels offset stored in EEPROM as two's complements value

$b_{i\_SCALE}$  is a scaling coefficient for slope of IR pixels offset and is stored in the EEPROM as unsigned value

$T_a$  is ambient temperature calculated in 15.1

$T_{a\_0} = 25^\circ C$  is a constant

**NOTE:** This applies to the compensation pixel as well ( $a_{CP}$  and  $b_{CP}$  while  $b_{i\_SCALE}$  is the same)

### 2. Thermal Gradient Compensation (TGC)

$$V_{IR(i,j)\_TGC\_COMP} = V_{IR(i,j)\_OFF\_COMP} - \frac{TGC}{32} \cdot V_{IR\_CP\_OFF\_COMP}$$

Where:

$V_{IR\_CP\_OFF\_COMP}$  is offset compensated IR signal of the thermal gradient compensation pixel

### 3. Emissivity compensation

$$V_{IR(i,j)\_COMPENSATED} = \frac{V_{IR(i,j)\_TGC\_COMP}}{\epsilon}$$

Where:

$\epsilon$  is emissivity coefficient. The scaled value is stored into EEPROM as unsigned value

$$\epsilon = \frac{256 \cdot \epsilon\_H + \epsilon\_L}{65535}$$

## 15.5 Calculating $\alpha(i,j)$

$$\alpha_{(i,j)} = \frac{(256 \cdot \alpha_{0\_H} + \alpha_{0\_L})}{2^{\alpha_{0\_SCALE}}} + \frac{\Delta\alpha_{(i,j)}}{2^{\Delta\alpha_{SCALE}}}$$

Where:

$\alpha_{0\_H}$ ,  $\alpha_{0\_L}$ ,  $\Delta\alpha_{(i,j)}$ ,  $\alpha_{0\_SCALE}$  and  $\Delta\alpha_{SCALE}$  are stored in the EEPROM as unsigned values

And parameters necessary to calculate To are stored into EEPROM at following addresses:

Tab 13: parameter used in calculation

EEPROM address	Cell name	Stored as	Parameter
0x00...0x3F	$a_{i(i,j)}$	2's complement	IR pixel individual offset coefficient
0x40...0x7F	$b_{i(i,j)}$	2's complement	Individual Ta dependence (slope) of IR pixels offset
0x80...0xBF	$\Delta\alpha_{(i,j)}$	unsigned	Individual sensitivity coefficient
0xD4	$a_{CP}$	2's complement	Compensation pixels individual offset coefficients
0xD5	$b_{CP}$	2's complement	Individual Ta dependence (slope) of the compensation pixel offset
0xD6	$\alpha_{CP\_L}$	unsigned	Sensitivity coefficient of the compensation pixel
0xD7	$\alpha_{CP\_H}$		
0xD8	$TGC$	2's complement	Thermal gradient coefficient
0xD9	$b_{i\_SCALE}$	unsigned	Scaling coefficient for slope of IR pixels offset
0xE0	$\alpha_{0\_L}$	unsigned	Common sensitivity coefficient of IR pixels
0xE1	$\alpha_{0\_H}$		
0xE2	$\alpha_{0\_SCALE}$	unsigned	Scaling coefficient for common sensitivity
0xE3	$\Delta\alpha_{SCALE}$	unsigned	Scaling coefficient for individual sensitivity
0xE4	$\varepsilon\_L$	unsigned	Emissivity
0xE5	$\varepsilon\_H$		

### 15.6 Example for To calculations

Let's assume that we have following EEPROM data for pixel  $i=2, j=8$ :

Tab 14: example of values while calculating object temperature

EEPROM address	Cell name	Stored as	Cell values (hex)
0x22	$a_{i(2,8)}$	2's complement	0xD6
0x62	$b_{i(2,8)}$	2's complement	0xC1
0xA2	$\Delta\alpha_{(2,8)}$	unsigned	0x8F
0xD4	$a_{CP}$	2's complement	0xD0
0xD5	$b_{CP}$	2's complement	0xCA
0xD6	$\alpha_{CP\_L}$	unsigned	0x00
0xD7	$\alpha_{CP\_H}$	unsigned	0x00
0xD8	$TGC$	2's complement	0x23
0xD9	$b_{i\_SCALE}$	unsigned	0x08
0xE0	$\alpha_{0\_L}$	unsigned	0xE4
0xE1	$\alpha_{0\_H}$	unsigned	0xD5
0xE2	$\alpha_{0\_SCALE}$	unsigned	0x2A
0xE3	$\Delta\alpha_{SCALE}$	unsigned	0x21
0xE4	$\varepsilon\_L$	unsigned	0x32
0xE5	$\varepsilon\_H$	unsigned	0xF3

Let's assume that we have the following input data:

$$V_{CP} = 0xFFD8 = 65496, \text{ decimal value}$$

$$\text{Sign check } 65496 > 32767 \rightarrow V_{CP} = 65496 - 65536 = -40$$

$$V_{IR(2,8)} = 0x0090 = 144, \text{ decimal value}$$

$$\text{Sign check } 144 < 32767 \rightarrow V_{IR(2,8)} = 144$$

$$Ta \approx 28.16^\circ C \text{ (as calculated in 15.1)}$$

Reference routine for To computation:

$$a_{CP} = 0xD0 = 208, \text{ decimal value}$$

$$\text{Sign check } 208 > 127 \rightarrow a_{CP} = 208 - 256 = -48$$

$$b_{CP} = 0xCA = 202, \text{ decimal value}$$

$$\text{Sign check } 202 > 127 \rightarrow b_{CP} = 202 - 256 = -54$$

$$V_{CP\_OFF\_COMP} = V_{CP} - \left( a_{CP} + \frac{b_{CP}}{2^{b_{i\_scale}}} (T_a - T_{a\_0}) \right) = -40 - \left( -48 + \frac{-54}{2^8} (28.16 - 25) \right) \approx 8.67$$

$$a_{i(2,8)} = 0xD6 = 214, \text{ decimal value}$$

$$\text{Sign check } 214 > 127 \rightarrow a_{i(2,8)} = 214 - 256 = -42$$

$$b_{i(2,8)} = 0xC1 = 193, \text{ decimal value}$$

$$\text{Sign check } 193 > 127 \rightarrow b_{i(2,8)} = 193 - 256 = -63$$

$$V_{IR(2,8)\_OFF\_COMP} = V_{IR(2,8)} - \left( a_{i(2,8)} + \frac{b_{i(2,8)}}{2^{b_{i\_scale}}} (T_a - T_{a\_0}) \right)$$

$$= 144 - \left( -42 + \frac{-63}{2^8} (28.16 - 25) \right) \approx 186.78$$

$$TGC = 0x23 = 35, \text{ decimal value}$$

$$\text{Sign check } 35 < 127 \rightarrow TGC = 35$$

$$V_{IR(i,j)\_TGC\_COMP} = V_{IR(i,j)\_OFF\_COMP} - \frac{TGC}{32} \cdot V_{IR\_CP\_OFF\_COMP} = 186.78 - \frac{35}{32} \cdot 8.67 \approx 177.30$$

$$\varepsilon = \frac{256 \cdot \varepsilon\_H + \varepsilon\_L}{65535} = \frac{256 \cdot 243 + 50}{65535} = \frac{62258}{65535} \approx 0.949996$$

$$V_{IR(i,j)\_COMPENSATED} = \frac{V_{IR(i,j)\_TGC\_COMP}}{\varepsilon} = \frac{177.30}{0.949996} \approx 186.63$$

$$\alpha_{(2,8)} = \frac{(256 \cdot \alpha_{0\_H} + \alpha_{0\_L})}{2^{\alpha_{0\_SCALE}}} + \frac{\Delta \alpha_{(2,8)}}{2^{\Delta \alpha_{SCALE}}} = \frac{(256 \cdot 213 + 228)}{2^{42}} + \frac{143}{2^{33}} \approx 2.9097 \cdot 10^{-8}$$

$$T_{O(2,8)} = \sqrt[4]{\frac{V_{IR(2,8)\_COMPENSATED}}{\alpha_{(2,8)}} + (T_a + 273.15)^4} - 273.15$$

$$T_{O(2,8)} = \sqrt[4]{\frac{186.63}{2.9097 \cdot 10^{-8}} + (28.16 + 273.15)^4} - 273.15 \approx 74.79^\circ\text{C}$$

## 16 Performance Graphs

### 16.1 Calculated Field Of View (FOV)

The FOV must be separated in this case in two directions, because the HTPA 16 x4 has 16 sensors in the width and 4 in the height.

Tab. 15: calculated field of view (FOV)

parameter			unit
	16 sensors	4 sensors	
Field of View L7.0	28.22	7.19	degree
Field of View L5.5	35.49	9.15	degree
Field of View L3.6	52.11	13.94	degree

## 17 Applications Information

### 17.1 Use of the HTPA 16x4 in I<sup>2</sup>C configuration

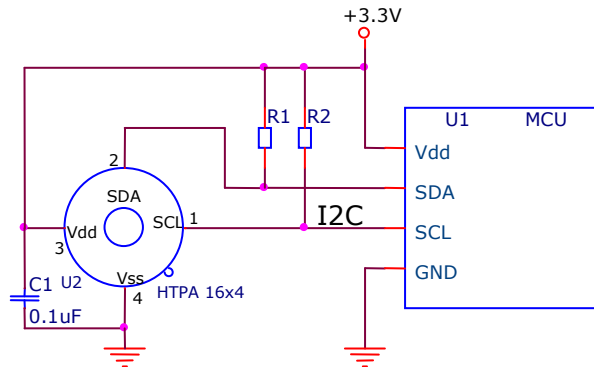

Figure 20: wire connection I<sup>2</sup>C

Figure 20 shows the connection of a HTPA 16x4 to an I<sup>2</sup>C with 3.3V power supply. The HTPA 16x4 has diode clamps SDA/SCL to Vdd so it is necessary to provide HTPA 16x4 with power in order not to load the I<sup>2</sup>C lines.

## 18 Application Comments

Significant **contamination** at the optical input side (sensor filter) might cause unknown additional filtering/distortion of the optical signal and therefore result in unspecified errors.

IR sensors are inherently susceptible to errors caused by **thermal gradients** from the front lens to the sensor die. This phenomenon is called "**heat shock**". When the front cap or lens emits more heat than the sensor die, the sensor receives more heat than it can compensate itself from its own ambient heat. Therefore the sensor is "shielded" and is not able to measure in specified ranges. In spite of the careful design of the HTPA 16x4 it is recommended not to subject the HTPA 16x4 to heat transfer and especially transient conditions. Front cap, front lens and sensor die should have the same ambient temperature.

The HTPA 16x4 is designed and calibrated to operate as a non contact thermometer in settled conditions. Using the thermometer in a very different way will lead to unknown results.

**Capacitive loading on a I<sup>2</sup>C** can degrade the communication. Some improvement is possible with use of current sources compared to resistors in pull-up circuitry. Further improvement is possible with specialized commercially available bus accelerators. With the HTPA 16x4 additional improvement is possible by increasing the pull-up current (decreasing the pull-up resistor values). Input levels for I<sup>2</sup>C compatible mode have higher overall tolerance than the I<sup>2</sup>C specification, but the output low level is rather low even with the high-power I<sup>2</sup>C specification for pull-up currents. Another option might be to go for a slower communication (clock speed), as the HTPA 16x4 implements Schmidt

triggers on its inputs in I<sup>2</sup>C compatible mode and is therefore not really sensitive to rise time of the bus (it is more likely the rise time to be an issue than the fall time, as far as the I<sup>2</sup>C systems are open drain with pull-up).

**Power dissipation** within the package may affect performance in two ways: by heating the "ambient" sensitive element significantly beyond the actual ambient temperature, as well as by causing gradients over the package that will inherently cause thermal gradient over the cap.

**Power supply decoupling** capacitor is needed as with most integrated circuits. HTPA 16x4 is a mixed-signal device with sensors, small signal analog part, digital part and I/O circuitry. In order to keep the noise low power supply switching noise needs to be decoupled. High noise from external circuitry can also affect noise performance of the device. In many applications a 100nF SMD ceramic capacitor close to the Vdd and Vss pins would be a good choice. It should be noted that not only the trace to the Vdd pin needs to be short, but also the one to the Vss pin. Using HTPA 16x4 with short pins improves the effect of the power supply decoupling.

## 19 Initialization

After POR is released the chip executes an initialization procedure, this procedure starts typ. 16ms after POR release and requires only a few ms. In that time the device will read its configuration from the reserved part of the EEPROM and will load it in the registers of the HTPA16x4. The settings that are loaded are:

- Oscillator trimming data
- Bias trimming data
- Regulator control
- ConfReg settings

During that time the HTPA16x4 will work as Master I<sup>2</sup>C device for the EEPROM chip. Note that this will not affect the external I<sup>2</sup>C bus, i.e. the information transmitted between HTPA16x4 and EEPROM chip will not be visible externally.

During the initialization, the HTPA16x4 will block any access through external I2C line and will not respond to any commands. This means that a NoACKN will be received by the external MCU if the HTPA16x4 or EEPROM chip is addressed.

## 20 Liability

The contents of this document are subject to change without notice. Changes or modifications at the product which haven't influence to the performance and/or quality of the device haven't to be announced to the customers in advance. Customers are requested to consult with Heimann Sensor representatives before the use of Heimann Sensor products in special applications where failure or abnormal operation may directly affect human lives or cause physical injury or property damage. The company or their representatives will not be responsible for damage arising from such use without prior approval.

## 21 Glossar

ADC	<b>A</b> nalog to <b>D</b> igital <b>C</b> onverter
DSP	<b>D</b> igital <b>S</b> ignal <b>P</b> rocessing
EMC	<b>E</b> lectro- <b>M</b> agnetic <b>C</b> ompatibility
ESD	<b>E</b> lectro- <b>S</b> tatic <b>D</b> ischarge
FOV	<b>F</b> ield <b>O</b> f <b>V</b> iew
FpS	<b>F</b> rames <b>p</b> er <b>S</b> econd (data refresh rate)
HFO	<b>H</b> igh <b>F</b> requency <b>O</b> scillator (RC type)
I <sup>2</sup> C	<b>I</b> nter- <b>I</b> ntegrated <b>C</b> ircuit communication protocol
IR	<b>I</b> nfra <b>R</b> ed
IR_data	<b>I</b> nfra <b>R</b> ed data (raw data from ADC proportional to IR energy received from the sensor)
MD	<b>M</b> aster <b>D</b> evice
NA	<b>N</b> ot <b>A</b> pplicable
POR	<b>P</b> ower <b>O</b> n <b>R</b> eset
PTAT	<b>P</b> roportional <b>T</b> o <b>A</b> bsolute <b>T</b> emperature sensor (package temperature)
SCL	<b>S</b> erial <b>C</b> lock
SD	<b>S</b> lave <b>D</b> evice
SDA	<b>S</b> erial <b>D</b> ata
Ta	<b>A</b> mbient <b>T</b> emperature
TGC	<b>T</b> emperature <b>G</b> radient <b>C</b> oefficient
TBD	<b>T</b> o <b>B</b> e <b>D</b> efined
To	<b>O</b> bject <b>T</b> emperature, 'seen' from IR sensor