

HMS Series

Miniature Thermopile Sensors for Remote Temperature Measurement and Gas Analysis

The HMS Series of CMOS compatible thermopile sensor chips in TO46 (or TO18) and even smaller transistor housings, features good sensitivity, small temperature coefficient of sensitivity as well as high reproducibility and reliability. The smaller package sizes benefit applications in which sensor mounting is a critical parameter. Especially the ultra small HMS Z11 F5.5 sensor with high symmetry (no orientation tap) opens new design and application possibilities. The HMS M-types offers the possibility to integrate an infrared lens into a TO46 housing and to reduce the field of view accordingly. The smaller chip TP1 is well suited for temperature measurements which require a precise measuring spot whereas the chip type TP2 offers higher signal.

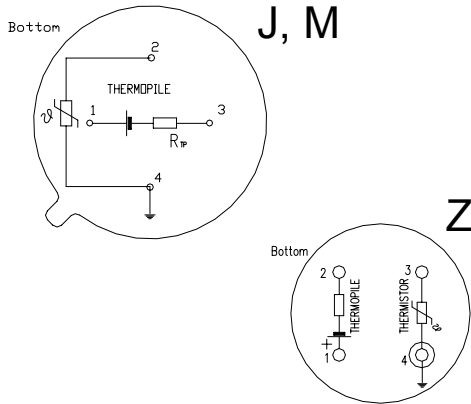

Ordering Information:

HMS / package shape / chip type /
w/wo thermistor / F desired filter type,
e.g.: HMS J11 F5.5

Parameter	HMS Z11	HMS J11	HMS J21	Unit
element size	0,61 ²	0,61 ²	1,2 ²	mm ²
voltage response ¹	13	13	39	V mm ² /W
sensitivity ¹	36	36	27	V/W
resistance R _{TP} ²	86	86	84	k Ohm
TC of resistance R _{TP} ²	0.02	0.02	0.02	% / K
noise ²	38	38	37	nV/ Hz ^{1/2}
detectivity ^{1,2}	5,6 10 ⁷	5.6 10 ⁷	8.7 10 ⁷	cm Hz ^{1/2} / W
time constant	< 6	<6	10	ms
thermistor reference ²	100	100	100	kOhm
temp.coeff.of thermistor B ³	3940	3940	3940	K
field of view ⁴	95	120	120	
operating temperature		-20...120		°C
storage temperature		-40...120		°C

- 1) filter type F5.5, Tobj=100°C, DC
- 2) at Tamb=25°C
- 3) 25°C, 50°C
- 4) degree at 50% signal level

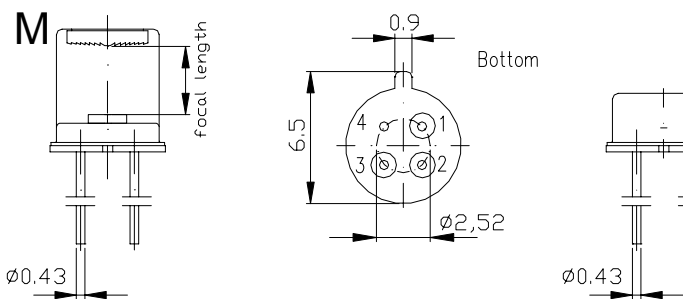

Filter types for temperature measurements

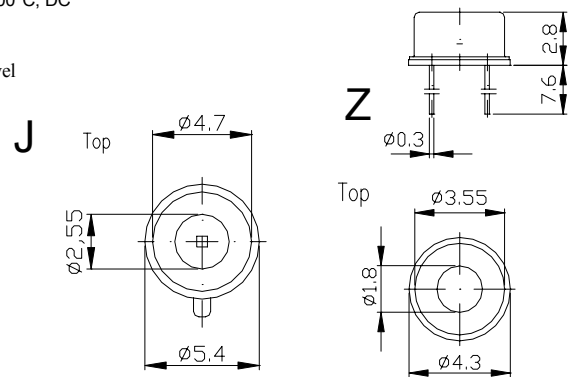

Filter types for Gas Analysis

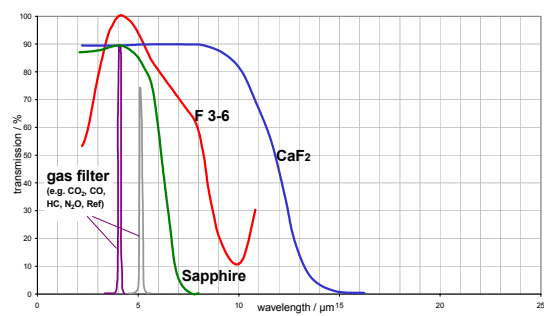
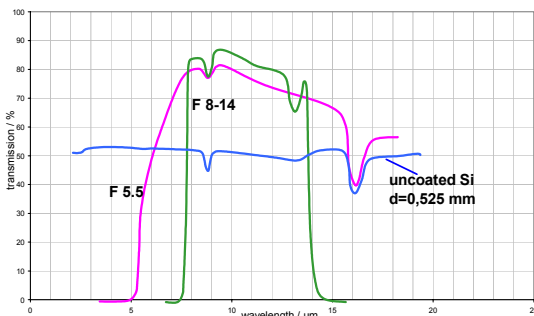

Modifications reserved Rev.07 / 01.10.2004